

PRDF14

PRODUCT SPECIFICATIONS

14 SEER DUAL FUEL
PACKAGED UNIT

FORM NO. PRDF14-100 (01/2017)

REFRIGERANT SYSTEM

- Environmentally friendly R410A refrigerant
- Copper tubing with enhanced fin coils
- Internal service gauge ports

HEAT EXCHANGER

- Aluminized Tri-Dimple tubular heat exchanger for increased efficiency
- L models comply with California Energy Commission Low NOx regulations
- Pest protected flue outlet

CABINET CONSTRUCTION

- Rounded corners for safety and an attractive, clean appearance
- One piece base design for strength and stability
- Drain ports for condensate management and coil runoff
- Low profile, with compact footprint
- Insulation to minimize heat loss plus reduce sound
- Textured pre-painted steel cabinet finish
- Superior service access to components
- One piece “no leak” top design

BLOWER

- Insulated compartment to reduce sound
- Efficient multispeed motor for wide airflow range
- Slide out blower housing for easy service

CONTROLS

- Direct spark ignition
- Integrated control boards with L.E.D. self diagnostics
- Defrost control board with field selectable time intervals
- High and low refrigerant pressure switches for system protection
- Built in short cycle protection to protect compressor
- Built in “quiet shift” operation during defrost
- Color coded wiring for easy service

INSTALLATION

- Horizontal or down discharge capable
- Utility connections on “right side”
- Tabbed duct flanges for simple duct connection

ACCESSORIES

- Hinged roofcurb
- Lifting brackets
- LP Gas Conversion
- Internal Filter Kits



WARRANTY

10 year limited parts and compressor warranty/lifetime heat exchanger warranty available. See limited warranty document for details.



MODEL NUMBER GUIDE

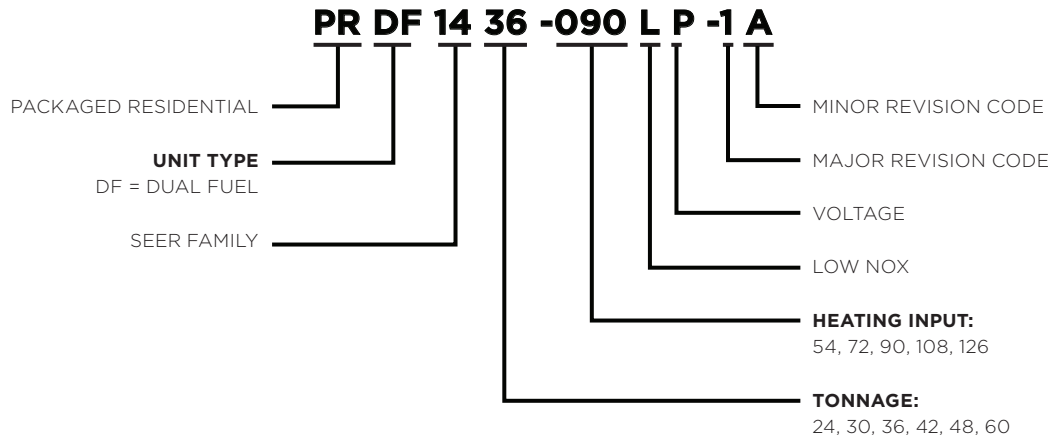

ELECTRICAL AND PHYSICAL DATA

Model	Voltage	Phase	Hz	Min Volts @ 60 hz	MCA	Max Fuse/HACR Breaker	Compressor		Condenser Motor		Blower Motor		Exhaust Motor		Refrig. Charge (oz.)	Weight (lbs.)					
							RLA	LRA	RLA	HP	RLA	HP	RLA	HP							
PRDF1424-072	208-230	1	60	197	17.4	25	10.9	59.3	1.0	1/6	2.8	1/3	0.22	1/50	80	348					
PRDF1430-072					20.7	30	13.5	72.5			96	356									
PRDF1436-072					24.4	35	15.4	83.9			81	366									
PRDF1436-090					24.4	40	15.9	85	1.7	1/4	2.8	1/3			165	466					
PRDF1442-072					27.0	45	18.0	117			1/2	163			471						
PRDF1442-090					39.7	60	24.3	144.2	7.6	1.0	161	484									
PRDF1448-126																					
PRDF1460-126																					

PERFORMANCE

MODEL	COOLING					HP HEATING					Sound dBA
	Rated AHRI Capacity Btuh	SEER	EER	Rated Sensible Capacity Btuh	CFM	47 DEG.		HSPF	17 DEG.		
						BTUH	COP		BTUH	COP	
PRDF1424	22,600	14.0	11.0	16,700	850	22,000	3.8	8.0	12,300	2.3	78
PRDF1430	28,600			21,700	1050	27,000	3.7		15,900		
PRDF1436	34,000			25,200	1250	33,400			20,000		
PRDF1442	40,000			30,800	1400	39,000	3.6		23,600		
PRDF1448	46,000			34,000	1600	45,000	3.7		27,000		
PRDF1460	57,000			41600	1800	56,000			33,600		

MODEL	Gas Heating			
	Input BTUH	Output BTUH	Efficiency AFUE	Temp Rise Range °F
PRDF1424-072	72,000	58,400	81	40-70
PRDF1430-072	72,000	58,400	81	40-70
PRDF1436-072	72,000	58,400	81	35-65
PRDF1436-090	90,000	72,900	81	40-70
PRDF1442-072	72,000	58,400	81	30-60
PRDF1442-090	90,000	72,900	81	40-70
PRDF1448-126	126,000	102,100	81	45-75
PRDF1460-126	126,000	102,100	81	45-75

**Certified in accordance with Unitary Air Conditioner Certification Program, which is based on AHRI Standard 210/240*

BLOWER PERFORMANCE

Model	Blower Tap	CFM @ ext. Static Pressure in in. wc without filter, dry coil							
		0.1	0.2	0.3	0.4	0.5	0.6	0.7	0.8
PRDF1424*	1	680	590	550	500	450	380		
	2	890	830	800	760	710	680	640	600
	3	1000	960	930	880	840	810	770	730
PRDF1430*	1	680	640	600	570	530	490		
	2	1100	1070	1050	1020	990	960	930	900
	3	1180	1160	1130	1090	1070	1040	1010	960
PRDF1436*	1	900	860	830	770	720	680	620	560
	2	1330	1280	1250	1230	1200	1180	1130	1100
	3	1520	1490	1460	1430	1380	1340	1250	1170
PRDF1442	2	1790	1740	1670	1590	1510	1410	1310	1210
	3	1500	1470	1430	1370	1310	1240	1140	1010
	4	1070	1050	1010	980	920	870	820	690
PRDF1448	2	1970	1890	1790	1690	1600	1510	1400	1280
	3	1730	1690	1600	1540	1450	1360	1270	1150
	4	1520	1480	1430	1370	1310	1230	1140	1050
PRDF1460*	1	1400	1320	1260	1200	1120	1060	980	900
	2	1920	1870	1820	1770	1720	1670	1450	1360
	3	2240	2200	2140	2100	2060	2020	1980	1950

* TAPs 4 & 5 designed for Heating
 Mid point temperatre rise @:
 Tap 4 - Nominal .2 ESP
 Tap 5 - Nominal .5 ESP

COOLING PERFORMANCE - EXTENDED RATINGS

Outdoor Model	Indoor Temp DB/ WB °F	Outdoor Temperature - DB °F														
		65°			82°			95°			105°			115°		
		Btuh	S/T	kW	Btuh	S/T	kW	Btuh	S/T	kW	Btuh	S/T	kW	Btuh	S/T	kW
PRDF1424	85/72	29,500	0.63	1.40	28,100	0.65	1.67	27,000	0.67	1.89	25,400	0.72	2.06	23,800	0.78	2.23
	80/67	27,800	0.70	1.39	26,300	0.72	1.65	24,800	0.74	1.89	23,300	0.80	2.07	21,800	0.86	2.24
	75/63	26,400	0.73	1.38	24,400	0.76	1.66	22,800	0.79	1.87	21,500	0.84	2.06	20,300	0.88	2.25
	75/57	23,300	1.00	1.38	21,800	1.00	1.65	20,600	1.00	1.86	20,100	1.00	2.05	19,500	1.00	2.25
PRDF1430	85/72	29,700	0.66	1.92	31,300	0.69	2.27	32,600	0.71	2.53	29,600	0.74	2.71	26,600	0.76	2.89
	80/67	33,500	0.71	1.89	32,700	0.74	2.18	30,100	0.76	2.48	27,900	0.80	2.69	25,600	0.84	2.90
	75/63	31,700	0.75	1.85	29,200	0.79	2.21	27,400	0.82	2.49	25,600	0.84	2.69	23,800	0.86	2.89
	75/57	29,900	1.00	1.87	27,500	1.00	2.24	25,800	1.00	2.52	24,500	1.00	2.71	23,300	1.00	2.89
PRDF1436	85/72	46,200	0.61	2.35	43,900	0.63	2.79	42,000	0.65	3.13	37,900	0.73	3.40	33,800	0.82	3.68
	80/67	43,800	0.67	2.33	41,000	0.71	2.73	37,100	0.74	3.10	34,000	0.81	3.38	30,900	0.88	3.66
	75/63	41,600	0.70	2.31	37,900	0.73	2.73	35,100	0.76	3.06	32,000	0.83	3.36	28,900	0.90	3.66
	75/57	34,500	1.00	2.30	31,600	1.00	2.72	29,300	1.00	3.05	28,700	1.00	3.35	28,100	1.00	3.65
PRDF1442	85/72	53,200	0.64	2.58	49,000	0.67	3.04	45,700	0.70	3.39	42,100	0.75	3.71	38,500	0.80	4.04
	80/67	49,800	0.72	2.56	44,800	0.75	2.98	40,700	0.77	3.38	38,000	0.82	3.72	35,300	0.88	4.05
	75/63	45,700	0.76	2.56	41,000	0.79	3.03	37,400	0.81	3.39	35,100	0.86	3.72	32,900	0.91	4.06
	75/57	41,200	1.00	2.55	37,800	1.00	3.02	35,200	1.00	3.38	33,500	1.00	3.72	31,900	1.00	4.06
PRDF1448	85/72	67,000	0.62	2.95	60,500	0.64	3.48	55,600	0.66	3.89	50,100	0.71	4.39	44,600	0.76	4.89
	80/67	60,400	0.68	2.94	51,700	0.73	3.44	48,400	0.74	3.93	44,700	0.78	4.40	41,100	0.83	4.87
	75/63	55,100	0.71	2.92	49,100	0.74	3.47	44,600	0.76	3.89	42,000	0.82	4.38	39,300	0.88	4.87
	75/57	47,100	1.00	2.91	43,100	1.00	3.44	40,100	1.00	3.84	39,000	1.00	4.35	38,000	1.00	4.86
PRDF1460	85/72	74,100	0.62	3.54	68,100	0.65	4.32	63,500	0.67	4.91	60,100	0.71	5.53	56,600	0.75	6.14
	80/67	69,200	0.69	3.51	63,000	0.71	4.24	57,700	0.73	4.85	55,000	0.78	5.48	52,400	0.82	6.10
	75/63	64,200	0.72	3.49	57,100	0.74	4.19	51,700	0.76	4.72	50,400	0.80	5.39	49,000	0.84	6.07
	75/57	57,500	1.00	3.44	51,700	1.00	4.21	47,300	1.00	4.80	46,900	1.00	5.42	46,500	1.00	6.04

HEATING PERFORMANCE EXT. RATINGS

Model	Outdoor Temp. DB/WB deg. F									
	0/0		17/15		35/33		47/43		62/56	
	Btuh	KW	Btuh	KW	Btuh	KW	Btuh	KW	Btuh	KW
PRDF1424	7000	1.55	12300	1.60	17900	1.68	22000	1710	27800	1.75
PRDF1430	9900	1.92	15900	2.00	22200	2.10	27300	2160	33000	2.23
PRDF1436	13500	2.49	20100	2.50	24100	2.59	34100	2730	40500	2.80
PRDF1442	14800	2.99	23600	3.10	33000	3.29	40000	3.36	48700	3.45
PRDF1448	18700	3.26	27000	3.40	35800	3.77	46400	3.91	57700	4.05
PRDF1460	20100	3.89	33700	4.10	48100	4.51	57000	4.78	67400	4.88

ACCESSORIES

Description	Where Used	Kit Number
Compressor Crankcase Heater	All	11X27
Compressor Hard Start Kit	24, 30, 36,48,60	10J42
Compressor Hard Start Kit	42	88M91
Down Flow Conversion - ACONVR836	24, 30, 36	1.851401
Down Flow Conversion - ACONVR837	42,48,60	1.851402
Drain pan overflow switch	All	11U75
Filter Rack Kit	24, 30, 36	11U73
Filter Rack Kit	42,48,60	11U74
Lifting Brackets	All	11U76
LPG/Propane Conversion Kit	All	11U77
Roof Curb	24, 30, 36	11U78
Roof Curb	42,48,60	11U79
Roof Curb	42,48,60	11U79
Sideflow Rect. to 14" Rounds Duct Adapter (Qty 25 sets)	24, 30, 36	R104617-01
	42, 48, 60	R104618-01
8" Height Full Perimeter Curb	24, 30, 36	14W71
8" Height Full Perimeter Curb	42, 48, 60	14W72
14" Height Full Perimeter Curb	24, 30, 36	14V68
14" Height Full Perimeter Curb	42, 48, 60	14V69

ROOF CURB DIMENSIONS

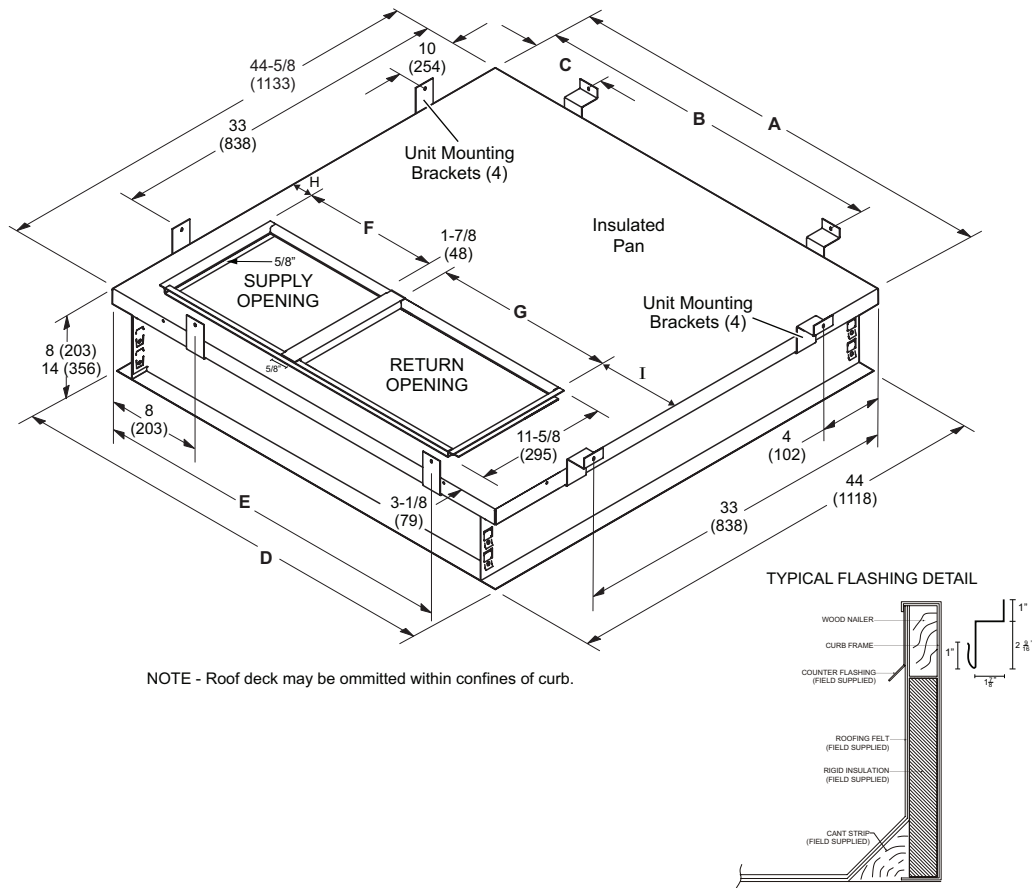

NOTE - Roof deck may be omitted within confines of curb.

Usage	A		B		C		D		E	
	in.	mm	in.	mm	in.	mm	in.	mm	in.	mm
24, 36	44-5/8	1133	43	1092	18	457	44	1118	37	940
48, 60	53-1/8	1349	51	1295	24	610	52-1/2	1334	41	1041
Usage	F		G		H		I			
	in.	mm	in.	mm	in.	mm	in.	mm		
24, 36	16.75	356	14.00	425	2	51	9-3/4	248		
48, 60	19.75	495	19.50	502	2	51	10	254		

DIMENSIONS (IN.)

Model	A	B	C	D	E	F	G	H	J
PRPDF1424	36.82	46.77	13.33	13.31	5.86	16.75	14	28.14	22.14
PRPDF1430									
PRPDF1436									
PRPDF1442	40.88	55.27	18.14	18.14	4.67	19.75	19.5	32.14	26.14
PRPDF1448									
PRPDF1460									

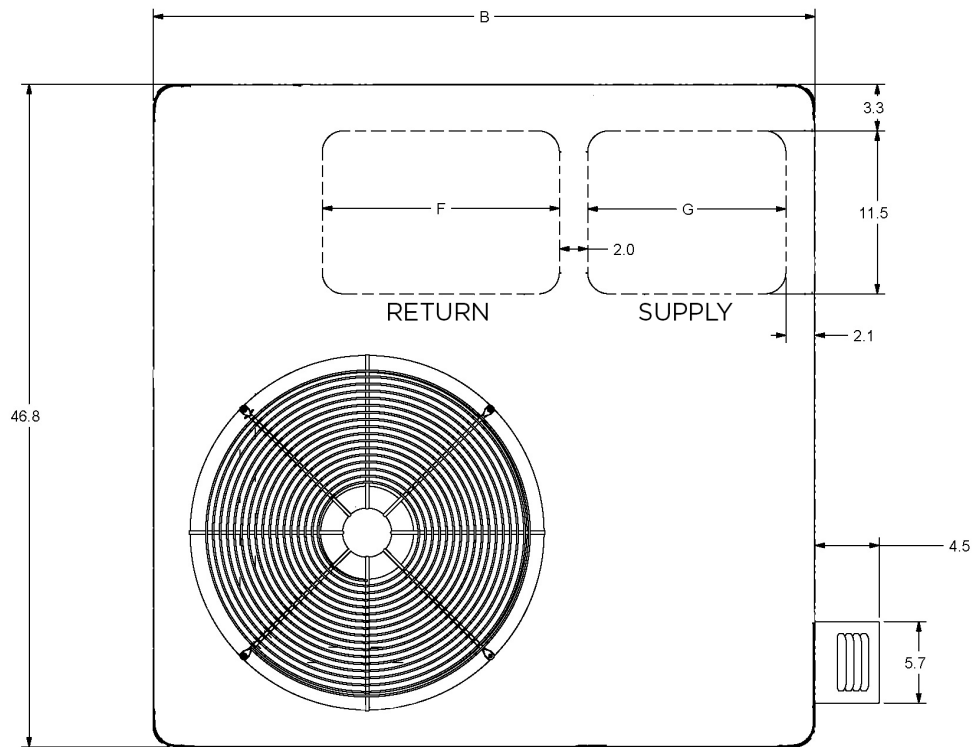
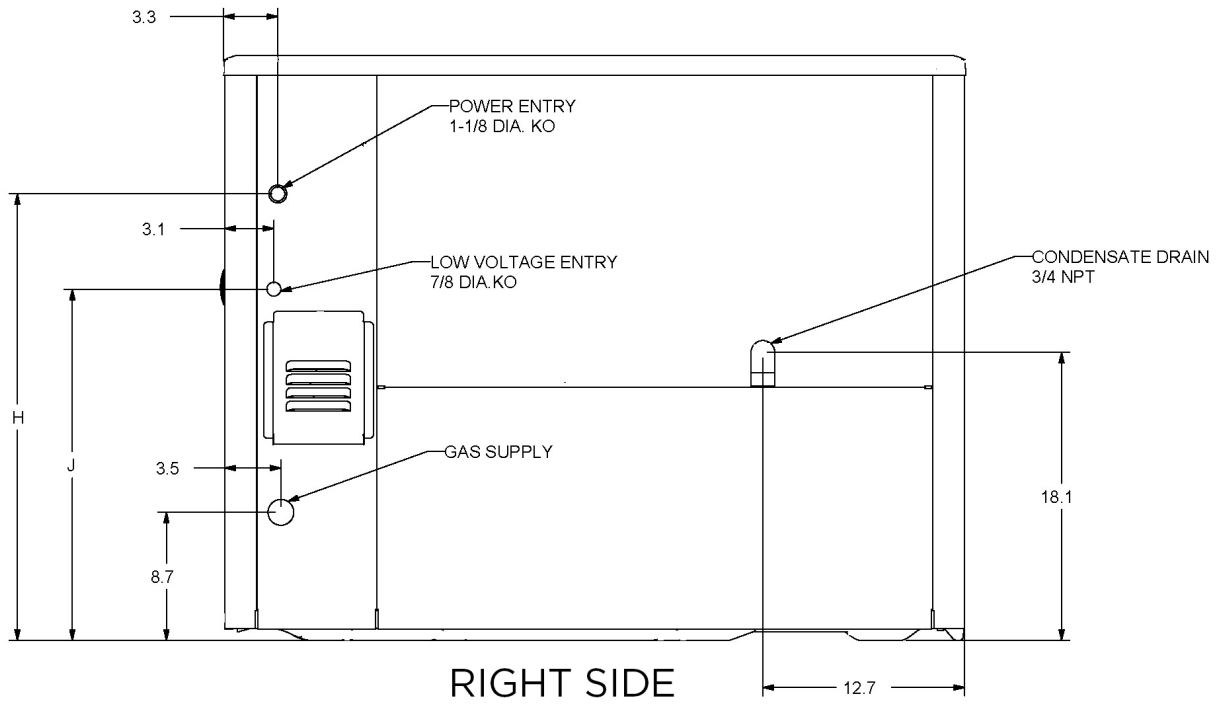

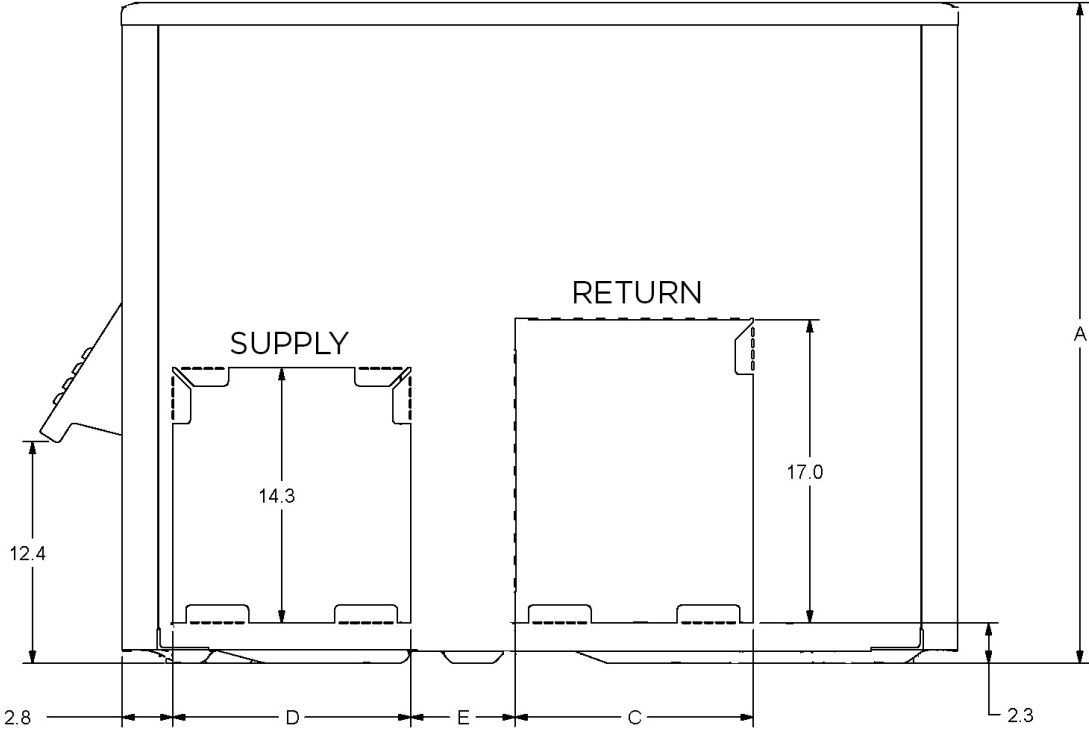



1-800-448-5872

All specifications and illustrations subject to change without notice and without incurring obligations.